

*ACO product catalogue*

**ACO GRP (Glass Reinforced Plastic) Separators**  
**Grease & Light Oil Separators | Sludge Trap**



**ACO. The future  
of drainage**



## **GRP (Glass Reinforced Plastic) Separators Grease & Light Oil Separators | Sludge Trap**



**collect:**  
Collect and  
remove



**clean:**  
Pre-clean and  
process



**hold:**  
Protect and  
attenuate



**release:**  
Pump, discharge and  
reuse



ACO system chain  
in action

## CONTENT

<b>Grease Separator</b>	<b>4</b>
<b>Grease Separator - Assembly concept</b>	<b>4</b>
<b>Lipumax G</b>	<b>6</b>
<b>Light Oil Separator</b>	<b>8</b>
<b>Light Oil Separator - Assembly concept</b>	<b>8</b>
<b>Oleopator G</b>	<b>10</b>
<b>Oleopator G-H</b>	<b>12</b>
<b>Oleopator-Bypass G</b>	<b>14</b>
<b>Sludge Trap</b>	<b>16</b>
<b>Sludge Trap - Assembly concept</b>	<b>16</b>
<b>Sludge Trap G-H</b>	<b>18</b>
<b>Top Sections</b>	<b>20</b>
<b>Top Sections for GRP Grease &amp; Light Oil Separators   Sludge Trap</b>	<b>20</b>
<b>Top Sections for Light Oil Separators</b>	<b>22</b>
<b>Accessories</b>	<b>23</b>
<b>Accessories for Oleopator G-H &amp; Sludge Trap G-H</b>	<b>23</b>

**Lipumax G - Assembly concept**

**Assembly parts**

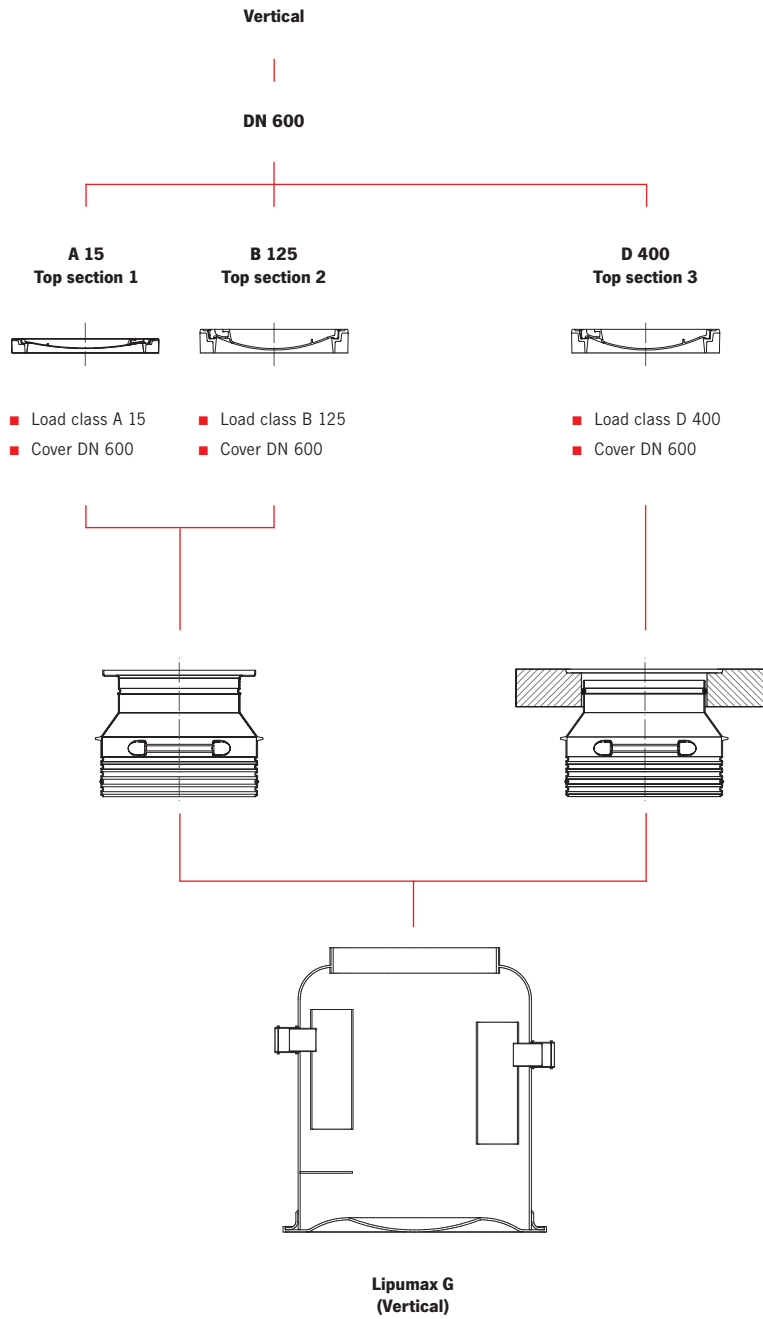

**Top sections DN 600**

**A 15**  
**Top section 1**

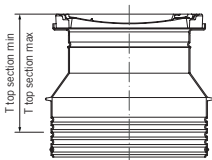

- Load class A 15
- Cover DN 600

**B 125**  
**Top section 2**

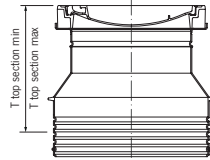

- Load class B 125
- Cover DN 600

**D 400**  
**Top section 3**

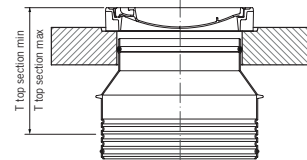

- Load class D 400
- Cover DN 600

**Bottom part**

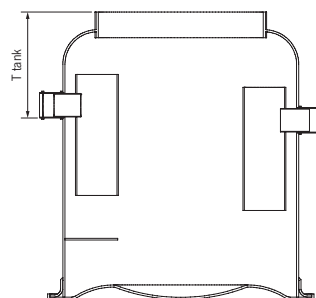

**Lipumax G**  
**(Vertical)**

**Calculation of Installation depth**

**Top section 1 - 3**

- $T_{total} = T_{tank} + T_{top\ section\ (min - max)}$

**Lipumax G**

**Product information**

**ACO Product benefits**

- Attractive purchase price and running costs
- Simple to install, requires less space
- Top section with odour proof sealed cover
- Integrated connection for sampling device
- Including rubber seal ring for connection with cover plate

- Tank made of reinforced plastic
- With integrated sludge trap
- One-piece construction
- With integrated connection for sampling
- Forsheda
- Inner parts made of PEHD

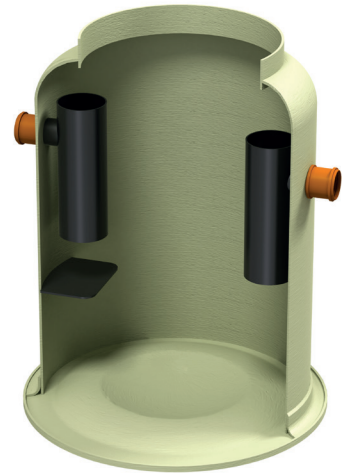

**Order information**

Nominal size	Inlet/outlet DN/OD [mm]	Volume			Weight [kg]	Item number
		Sludge trap [l]	Grease storage [l]	Total capacity [l]		
1	100	100	180	518	88	12501.01
1-2	100	200	180	620	93	12502.01
2	100	400	210	816	105	12509.01
4	150	400	210	816	110	12503.01
4	150	800	320	1387	127	12510.01
7	150	700	290	1444	130	12504.01
7	150	1400	750	2660	196	12511.01
10	150	1000	400	2272	180	12505.01
10	150	2000	1140	3358	185	12512.01
15	200	1500	1120	3399	600	12515.01
15	200	3000	1120	4874	640	12513.01
20	200	2000	1140	3882	620	12517.01
20	200	4000	1140	5879	680	12516.01
25	250	2500	1160	5287	550	12518.01
25	250	5000	1140	7795	654	12514.01

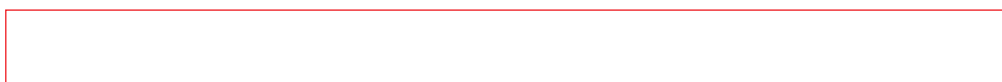

**Dimensions**

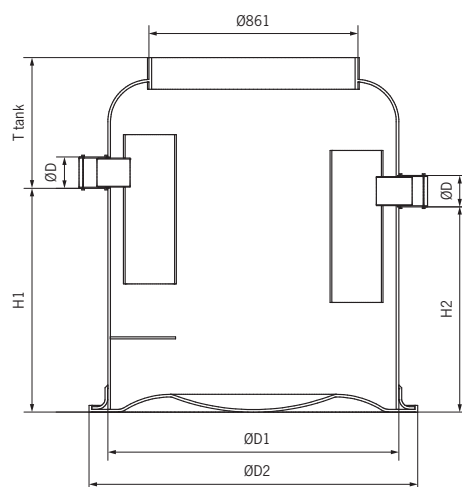

Nominal size	Item number	Dimension				
		H1 [mm]	H2 [mm]	ØD1 [mm]	ØD2 [mm]	T tank [mm]
1	12501.01	740	670	1000	1240	440
1-2	12502.01	870	800	1000	1240	440
2	12509.01	1120	1050	1000	1240	440
4	12503.01	1120	1050	1000	1240	490
4	12510.01	1330	1260	1200	1400	560
7	12504.01	1380	1310	1200	1400	560
7	12511.01	1600	1530	1500	1720	640
10	12505.01	1380	1310	1500	1720	620
10	12512.01	1995	1925	1500	1720	640
15	12515.01	1430	1360	1800	2040	790
15	12513.01	2010	1940	1800	2040	790
20	12517.01	1620	1550	1800	2040	790
20	12516.01	2405	2335	1800	2040	800
25	12518.01	1560	1490	2200	2440	790
25	12514.01	2220	2150	2200	2440	790

**Light Oil Separator - Assembly concept**

**Assembly parts**

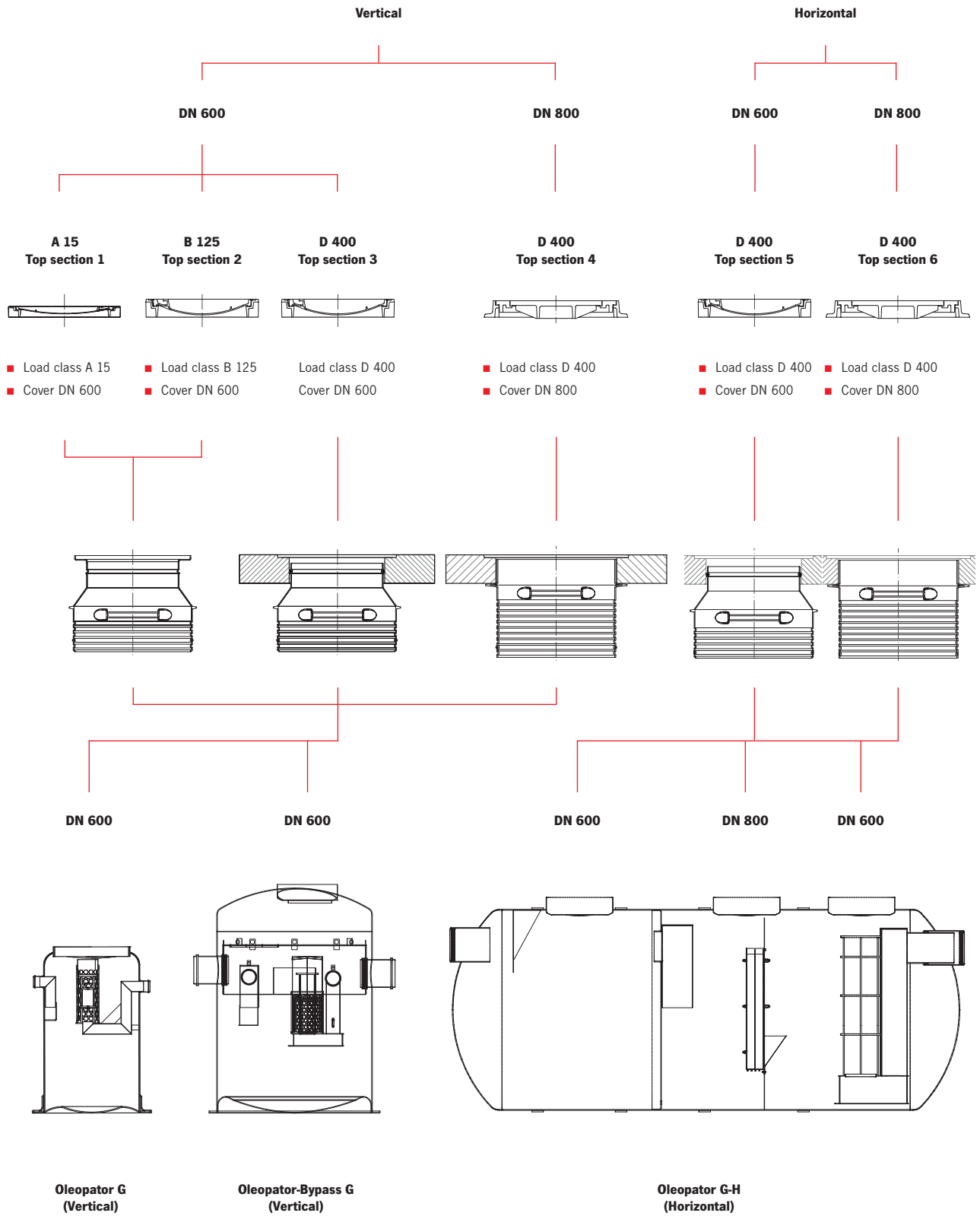



### Top sections DN 600

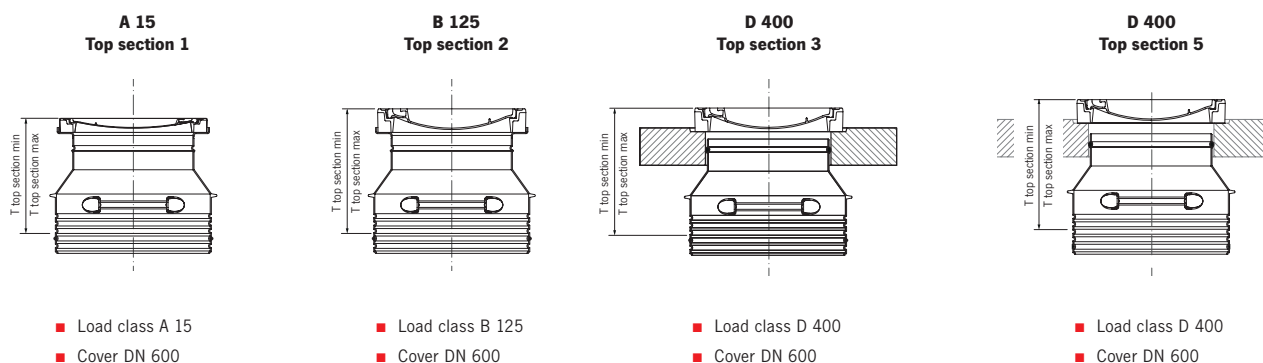

### Top sections DN 800



### Bottom part

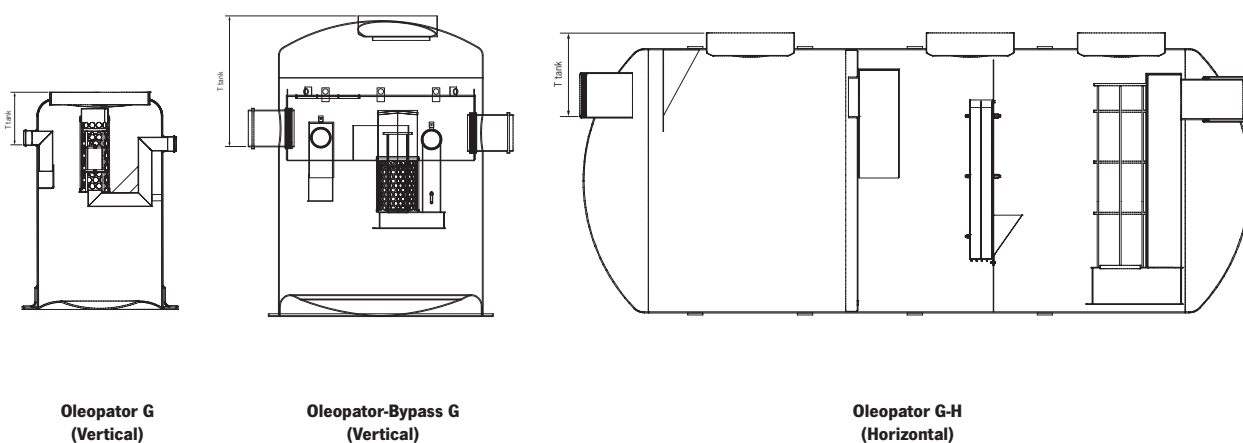

### Calculation of Installation depth

#### Top section 1 - 6

- T total = T tank + T top section (min - max)

- DN 600 shall be max. 600 mm
- DN 800 shall be max. 3000 mm

**Oleopator G**

**Product information**

**ACO Product benefits**

- All nominal sizes tested by regional test institute (LGA)
- DOP
- Optimum accessibility guaranteed for maintenance, cleaning and disposal thanks to removable cage component
- Coalescence insert can be removed for cleaning without having to empty the separator
- Integrated connection for sampling device

- Tank made of glass reinforced plastic
- With coalescence insert (filter)
- Inner parts made of PEHD

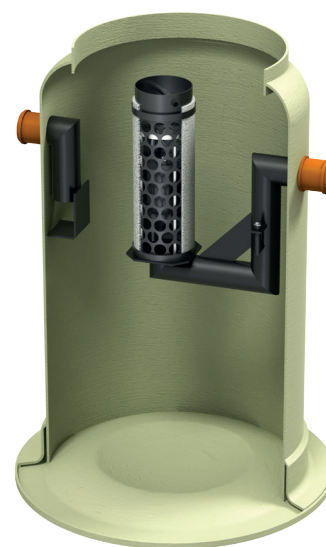

**Order information**

Nominal size	Inlet/outlet DN/OD [mm]	Volume			Weight [kg]	Top section diameter	Item number
		Sludge trap [l]	Oil storage [l]	Total capacity [l]			
3	100	300	163	604	105	D600	12601.01
3	100	600	163	903	105	D600	12602.01
3	100	900	232	1297	172	D600	12603.01
6	150	600	160	887	169	D600	12611.01
6	150	1200	232	1602	182	D600	12612.01
6	150	1800	576	2413	233	D600	12613.01
10	150	1000	273	1534	197	D600	12621.01
10	150	2000	576	2784	254	D600	12622.01
10	150	3000	1139	4755	705	D600	12623.01
15	200	1500	464	2360	310	D600	12631.01
15	200	3000	944	3914	525	D600	12632.01
20	200	4000	1163	5857	565	D600	12642.01
20	200	6000	1163	7909	618	D600	12643.01
20	200	2000	1163	3243	505	D600	12645.01
30	250	3000	1513	5705	515	D600	12651.01
30	250	6000	1613	8555	613	D600	12652.01
40	300	4000	1350	7225	630	D600	12661.01
50	300	5000	1350	8213	650	D600	12671.01



**Dimensions**

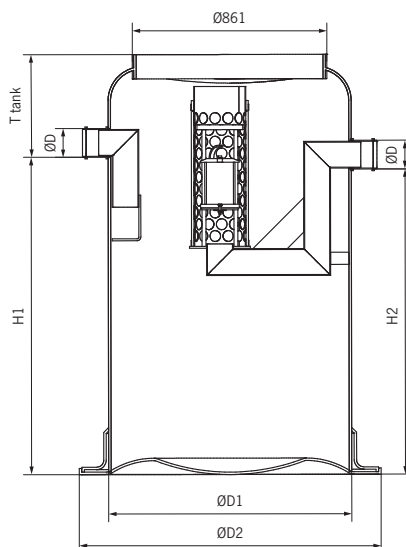

Nominal size	Item number	Dimension				
		H1 [mm]	H2 [mm]	ØD1 [mm]	ØD2 [mm]	T tank [mm]
3	12601.01	800	780	1000	1240	400
3	12602.01	1180	1160	1000	1240	400
3	12603.01	1200	1180	1200	1400	460
6	12611.01	1160	1140	1000	1240	460
6	12612.01	1470	1450	1200	1400	570
6	12613.01	1410	1390	1500	1720	630
10	12621.01	1410	1390	1200	1400	590
10	12622.01	1620	1600	1500	1720	560
10	12623.01	1370	1350	2200	2440	640
15	12631.01	1380	1360	1500	1720	660
15	12632.01	2260	2240	1500	1720	600
20	12642.01	1660	1640	2200	2440	780
20	12643.01	2200	2180	2200	2440	690
20	12645.01	1880	1860	1500	1720	660
30	12651.01	1620	1600	2200	2440	730
30	12652.01	2370	2350	2200	2440	720
40	12661.01	2020	2000	2200	2440	830
50	12671.01	2280	2260	2200	2440	960

**Oleopator G-H**

**Product information**

- ACO Product benefits**
- All nominal sizes tested by regional test institute (LGA)
  - DOP
  - Optimum accessibility guaranteed for maintenance, cleaning and disposal thanks to removable cage component
  - Coalescence insert can be removed for cleaning without having to empty the separator
  - Integrated connection for sampling device

- Tank made of glass reinforced plastic
- With coalescence insert (filter)
- Inner parts made of PEHD

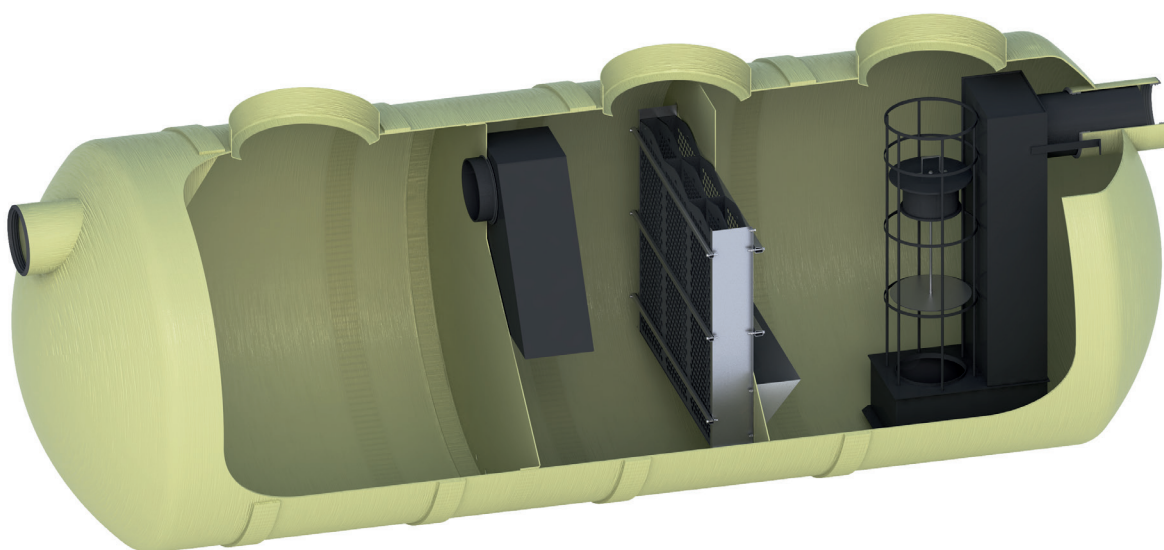

**Order information**

Nominal size	Inlet/outlet DN/OD [mm]	Volume			Weight [kg]	Item number
		Sludge trap [l]	Oil storage [l]	Total capacity [l]		
65	300	6500	4500	17013	1500	<b>12856.01</b>
80	400	8000	4500	18251	1600	<b>12857.01</b>
100	400	10 000	4500	18914	1800	<b>12858.01</b>

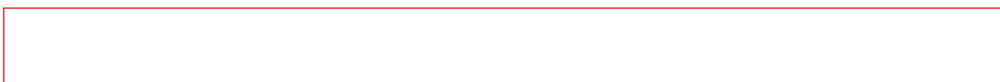

**Dimensions**

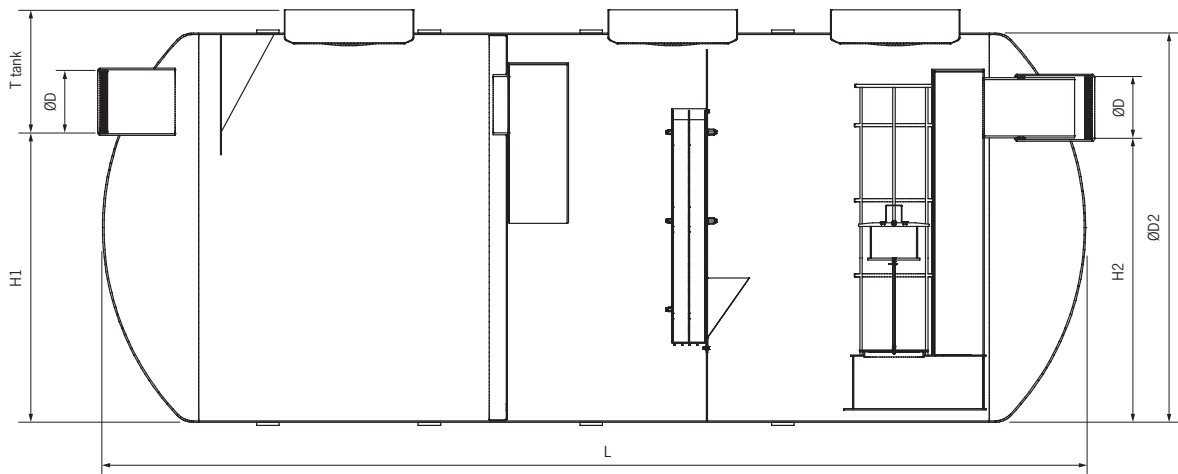

Nominal size	Item number	Dimension						ACO Belt *	Quantity of Top Sections	
		H1 [mm]	H2 [mm]	ØD1 [mm]	ØD2 [mm]	T tank [mm]	L [mm]		[DN 600]	[DN 800]
65	<b>12856.01</b>	1744	1704	2380	2402	813	6125	6	2	1
80	<b>12857.01</b>	1744	1704	2380	2402	813	6505	6	2	1
100	<b>12858.01</b>	1744	1704	2380	2402	813	7025	7	2	1

\* Use in case of occurrence groundwater

**Oleopator-Bypass G**

**Product information**

**ACO Product benefits**

- Option for drainage of large areas in combination with traditional separator technology
  - All functions integrated in a single tank
  - Takes up little space
  - Integrated connection for sampling device
- 
- Tank made of glass reinforced plastic
  - With coalescence insert (filter)
  - Pipe connection using suitable push sockets or pipe connectors (no welded sockets)
  - With bypass channel and integrated bypass control
  - One-piece construction
  - Application examples:
    - Parking surfaces
    - Industrial surfaces
  - Inner parts made of PEHD

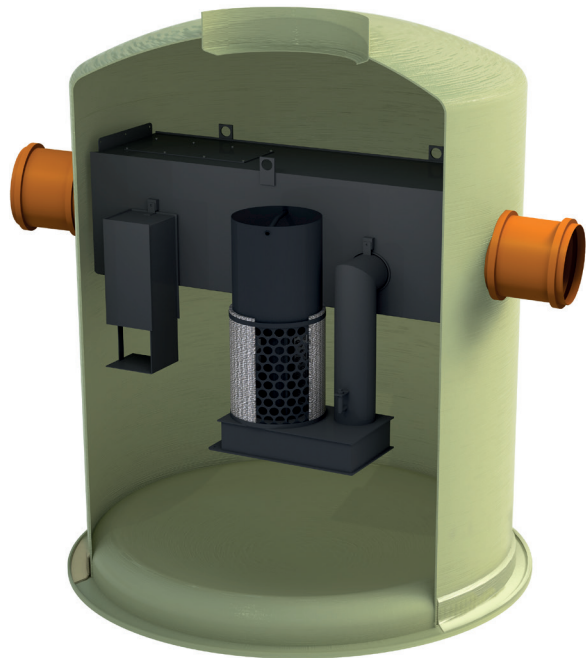

**Order information**

Nominal size	Inlet/outlet DN/OD [mm]	Max. Flow [l/s]	Volume			Weight [kg]	Item number
			Sludge trap [l]	Oil storage [l]	Total capacity [l]		
6	300	60	600	171	1318	275	12541.01
6	300	60	1200	171	1936	303	12542.01
6	300	60	1800	171	2554	331	12543.01
8	300	80	800	171	1530	284	12544.01
8	300	80	1600	171	2325	320	12545.01
8	300	80	2400	171	3120	357	12546.01
10	400	100	1000	171	1760	318	12547.01
10	400	100	2000	171	2749	363	12548.01
10	400	100	3000	171	3738	405	12549.01
15	400	150	1500	444	3311	478	12550.01
15	400	150	3000	444	4698	520	12551.01
15	400	150	4500	444	6370	566	12552.01
20	400	200	2000	570	4413	477	12553.01
20	400	200	4000	570	6427	519	12554.01
20	400	200	6000	570	8403	566	12555.01
30	500	300	3000	612	5439	564	12556.01
30	500	300	6000	612	8441	708	12557.01
30	500	300	9000	612	11442	801	12558.01

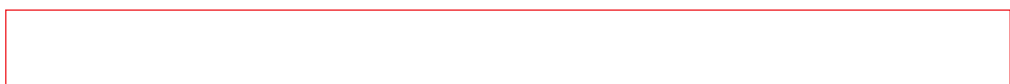

**Dimensions**

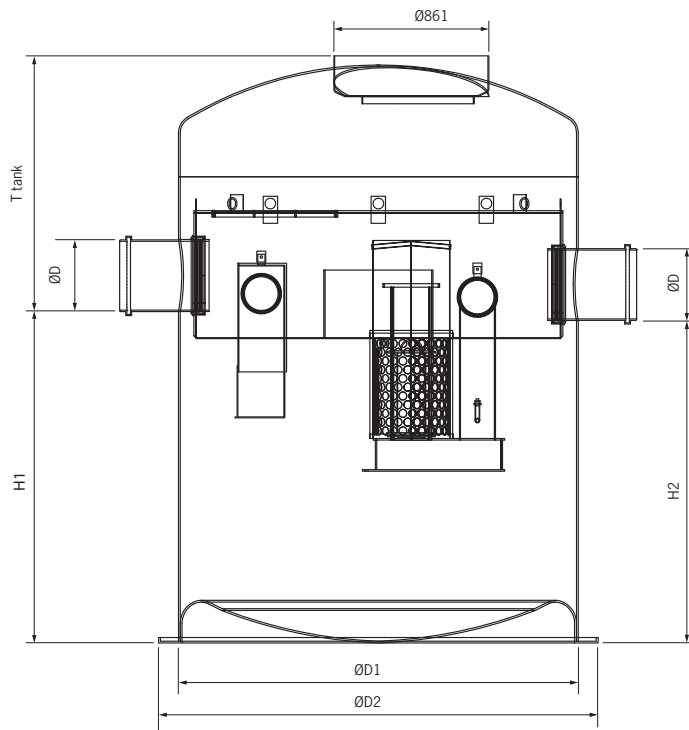

Nominal size	Item number	Dimension				
		H1 [mm]	H2 [mm]	ØD1 [mm]	ØD2 [mm]	T tank [mm]
6	12541.01	820	770	1500	1720	880
6	12542.01	1170	1120	1500	1720	875
6	12543.01	1520	1470	1500	1720	875
8	12544.01	940	890	1500	1720	875
8	12545.01	1390	1340	1500	1720	875
8	12546.01	1840	1790	1500	1720	875
10	12547.01	1070	1020	1500	1720	1060
10	12548.01	1630	1580	1500	1720	1060
10	12549.01	2190	2140	1500	1720	1020
15	12550.01	1020	970	2200	2440	1270
15	12551.01	1385	1335	2200	2440	1265
15	12552.01	1825	1775	2200	2440	1215
20	12553.01	1360	1260	2200	2440	1370
20	12554.01	1840	1790	2200	2440	1420
20	12555.01	2360	2310	2200	2440	1420
30	12556.01	1630	1530	2200	2440	1360
30	12557.01	2420	2320	2200	2440	1360
30	12558.01	3210	3110	2200	2440	1360

**Sludge Trap - Assembly concept**

**Assembly parts**

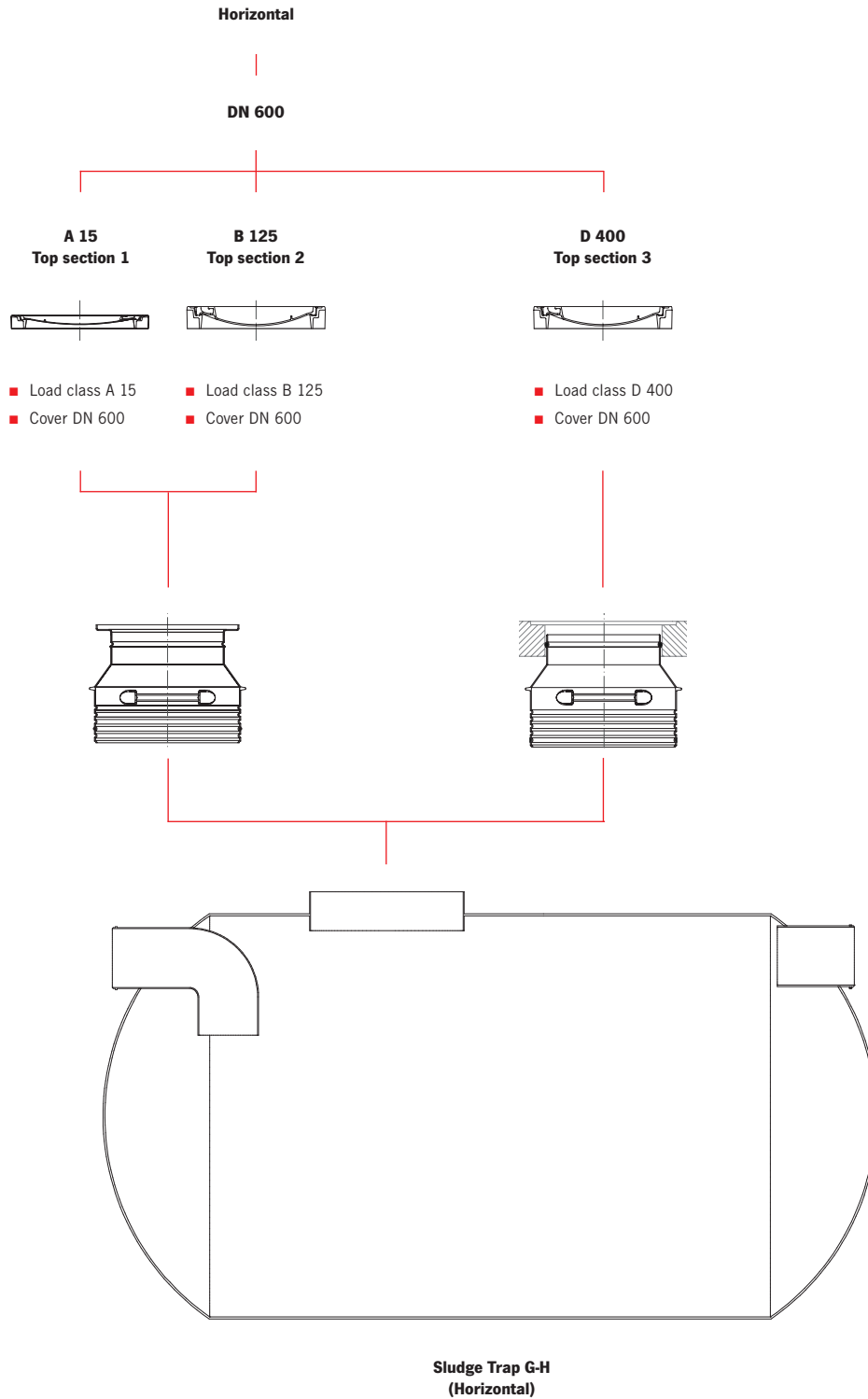



### Top sections DN 600

**A 15**  
Top section 1

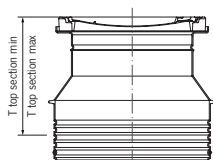

- Load class A 15
- Cover DN 600

**B 125**  
Top section 2

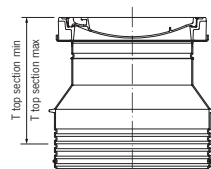

- Load class B 125
- Cover DN 600

**D 400**  
Top section 3

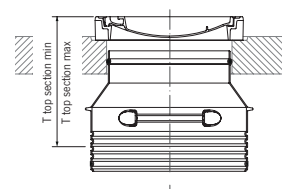

- Load class D 400
- Cover DN 600

### Bottom part

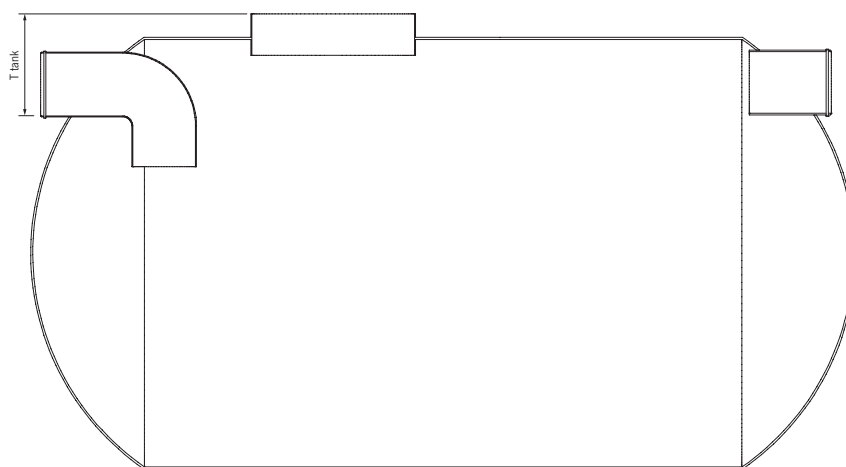

**Sludge Trap G-H**  
(Horizontal)

### Calculation of Installation depth

#### Top section 1 - 3

- $T_{total} = T_{tank} + T_{top\ section\ (min - max)}$

**Sludge Trap G-H**

**Product information**

**ACO Product benefits**

- Attractive purchase price and running costs
- Simple to install, requires less space
- Integrated connection for sampling device

- Tank made of reinforced plastic
- With integrated sludge trap
- One-piece construction
- With integrated connection for sampling
- Forsheda
- Inner parts made of PEHD

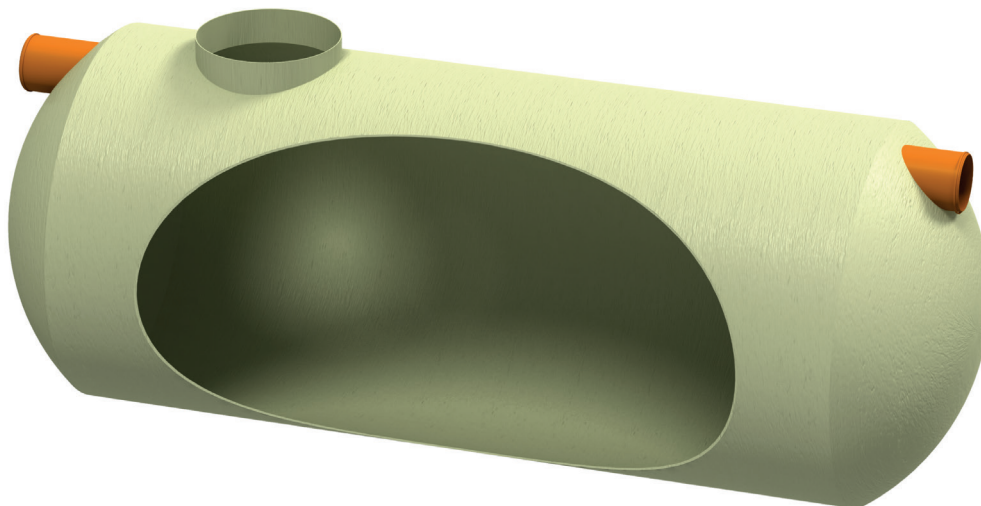

**Order information**

Volume Sludge trap [l]	Inlet/outlet DN/OD [mm]	Volume Total capacity [l]	Weight [kg]	Item number
3000	200	3034	238	12800.01
6500	200	6559	373	12801.01
10000	250	10001	490	12802.01
15000	250	15003	734	12803.01
20000	315	20155	859	12804.01
30000	315	30260	1470	12805.01
40000	400	40008	1918	12806.01
48000	400	48357	1998	12810.01
70000	400	71461	2896	12808.01

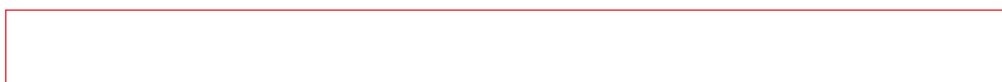

**Dimensions**

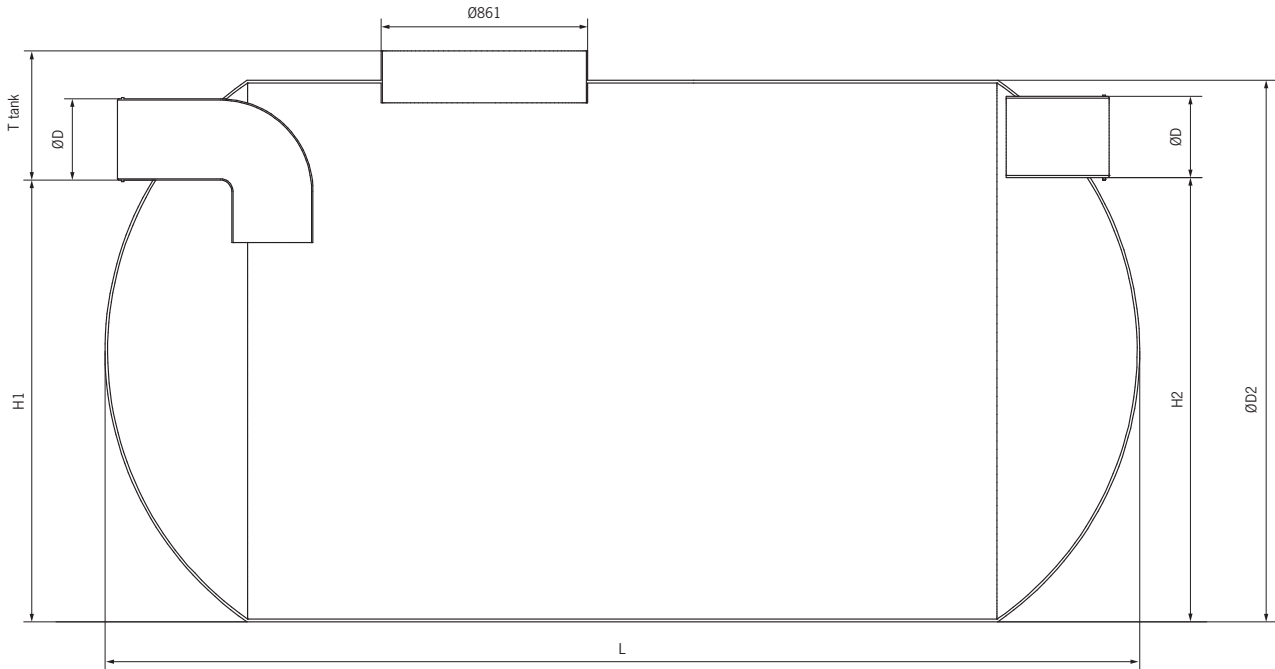

Volume Sludge trap [l]	Item number	Dimension						ACO Belt * [pcs]
		H1 [mm]	H2 [mm]	ØD1 [mm]	ØD2 [mm]	T tank [mm]	L [mm]	
3000	<b>12800.01</b>	1030	980	1200	1220	290	3280	2
6500	<b>12801.01</b>	1630	1580	1800	1820	290	3145	2
10000	<b>12802.01</b>	1580	1530	1800	1820	340	4705	3
15000	<b>12803.01</b>	1880	1830	2100	2120	340	5065	4
20000	<b>12804.01</b>	1815	1765	2100	2120	405	6865	5
30000	<b>12805.01</b>	1945	1895	2200	2220	375	9260	7
40000	<b>12806.01</b>	1860	1810	2200	2220	460	12260	10
48000	<b>12810.01</b>	2040	1990	2380	2402	462	13400	12
70000	<b>12808.01</b>	2230	2180	2570	2590	460	15700	20

\* Use in case of occurrence groundwater

**Top Sections for GRP Grease & Light Oil Separators | Sludge Trap**

**Top section 1 - load class A 15 / DN 600**

**Order information**

- ACO Product benefits**
- Load class A 15 according to EN 124
  - Frame from concrete, cover from cast iron
  - Clear opening Ø 600 mm
  - Cover odour proof sealed
  - Raising tube from polyethylene

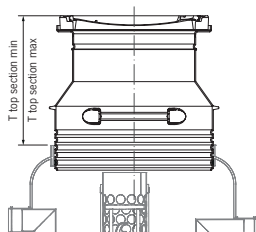

T top section (min-max)* [mm]	Manhole cover [mm]	Light Oil & Sludge Trap		Grease	
		Weight [kg]	Item number	Weight [kg]	Item number
520-640	Ø 600	97	3301.34.11	97	3300.34.11
520-1090	Ø 600	103	3301.34.12	105	3300.34.12
520-1690	Ø 600	113	3301.34.13	116	3300.34.13

**Top section 2 - load class B 125 / DN 600**

**Order information**

- ACO Product benefits**
- Load class B 125 according to EN 124
  - BEGU cover
  - Clear opening Ø 600 mm
  - Cover odour proof sealed
  - Raising tube from polyethylene

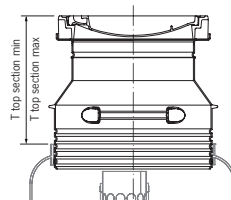

T top section (min-max)* [mm]	Manhole cover [mm]	Light Oil & Sludge Trap		Grease	
		Weight [kg]	Item number	Weight [kg]	Item number
550-670	Ø 600	115	3301.35.11	110	3300.35.11
550-1120	Ø 600	123	3301.35.12	118	3300.35.12
550-1720	Ø 600	134	3301.35.13	128	3300.35.13

Note\*: T total = T tank + T top section (min-max)

**Top section 3 - load class D 400 / DN 600**

**Order information**

**ACO Product benefits**

- Load class D 400 according to EN 124
- BEGU cover
- Clear opening Ø 600 mm
- Cover odour proof sealed
- Raising tube from polyethylene
- Selectively with load distribution plate from concrete

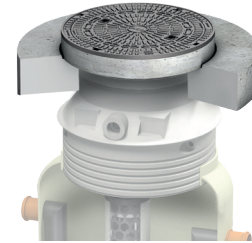
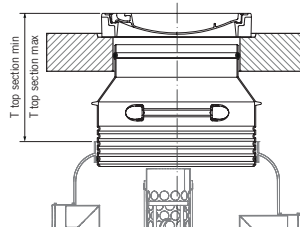

T top section (min-max)* [mm]	Manhole cover [mm]	Light Oil & Sludge Trap		Grease	
		Weight [kg]	Item number	Weight [kg]	Item number
550-655	Ø 600	846	3301.36.08	846	3300.36.08
550-1130	Ø 600	854	3301.36.09	854	3300.36.09
550-1730	Ø 600	866	3301.36.10	866	3300.36.10
550-655 (without load distribution plate)	Ø 600	186	3301.37.08	186	3300.37.08
550-1130 (without load distribution plate)	Ø 600	194	3301.37.09	194	3300.37.09
550-1730 (without load distribution plate)	Ø 600	198	3301.37.10	198	3300.37.10

**Top section 4 - load class D 400 / DN 800**

**Order information**

**ACO Product benefits**

- Load class D 400 according to EN 124
- Cover from cast iron
- Clear opening Ø 800 mm
- Cover odour proof sealed
- Raising tube from polyethylene
- Selectively with load distribution plate from concrete
- For Oleopator G - FST NS 40 - 50

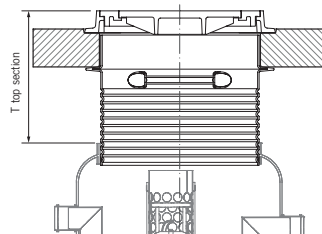

T top section [mm] (min)*	Manhole cover [mm]	Weight [kg]	Item number
505-715	Ø 800	1161	418951
500-1645	Ø 800	1194	418906
525-735 (without load distribution plate)	Ø 800	261	418950
500-1645 (without load distribution plate)	Ø 800	272	418905

**Top Sections for GRP Light Oil Separators**

**Top section 5 - load class D 400 / DN 600**

**Order information**

- ACO Product benefits**
- Load class B 125 and D 400 according to EN 124
  - BEGU cover
  - Clear opening Ø 600 mm
  - Cover odour proof sealed
  - Raising tube from polyethylene
  - Selectively with load distribution plate from concrete
  - For Oleopator G-H - FST NS 65 - 100

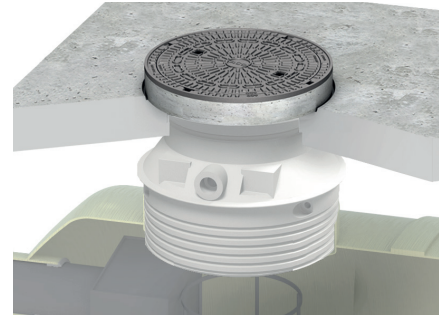
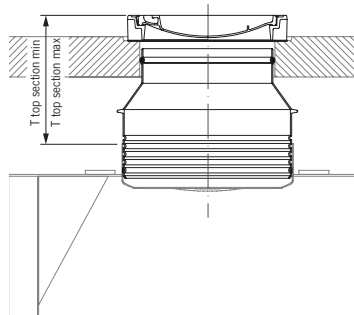

T top section (min-max)* [mm]	Manhole cover [mm]	Light Oil - Oleopator G-H	
		Weight [kg]	Item number
550-655 (without load distribution plate)	Ø 600	186	3301.37.08
550-1130 (without load distribution plate)	Ø 600	194	3301.37.09
550-1730 (without load distribution plate)	Ø 600	198	3301.37.10

**Top section 6 - load class D 400 / DN 800**

**Order information**

- ACO Product benefits**
- Load class B 125 and D 400 according to EN 124
  - Cover from cast iron
  - Clear opening Ø 800 mm
  - Cover odour proof sealed
  - Raising tube from polyethylene
  - Selectively with load distribution plate from concrete
  - For Oleopator G-H - FST NS 65 - 100

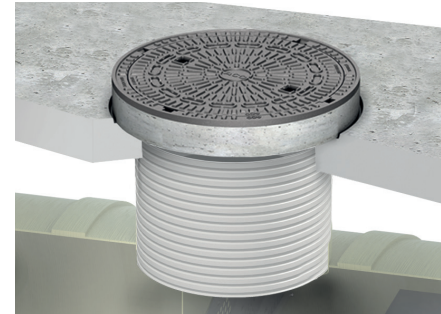
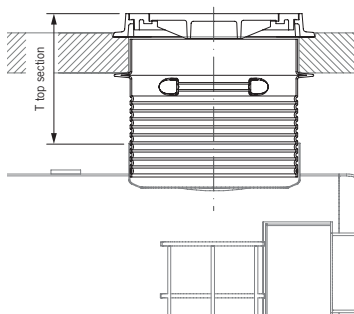

T top section (min-max)* [mm]	Manhole cover [mm]	Light Oil - Oleopator G-H	
		Weight [kg]	Item number
525-735 (without load distribution plate)	Ø 800	261	418950
500-1645 (without load distribution plate)	Ø 800	272	418905

Note\*: T total = T tank + T top section (min-max)

**Accessories for Oleopator G-H & Sludge Trap G-H**

**Order information**

	<b>Product description</b>	<b>Model</b>	<b>Item number</b>
	<p><b>ACO Belt 120 SS</b></p> <ul style="list-style-type: none"> <li>■ Load strap: Polyester</li> <li>■ Tensioner and hooks: Stainless steel</li> <li>■ For Oleopator G-H - FST NS 65 - 100</li> </ul>	<ul style="list-style-type: none"> <li>■ 12 m</li> </ul>	<p><b>2565.270</b></p>

**ACO Industries Tábor s.r.o.**

Prumyslova 1158  
391 01 Sezimovo Usti  
Czech Republic

[www.aco.com](http://www.aco.com)

**ACO. The future of drainage**

All reasonable care has been taken in compiling the information in this document. All recommendations and suggestions on the use of ACO products are made without guarantee since the conditions of use are beyond the control of the Company. It is the customer's responsibility to ensure that each product is fit for its intended purpose and that the actual conditions of use are suitable. This brochure and any advice is provided free of charge and accordingly on terms that no liability (including liability for negligence) will attach the Company or its servants or agents arising out of or in connection with or in relation to this brochure or any such advice. Any goods supplied by the Company will be supplied solely upon its standard conditions of sale, copies of which are available on request. The Company's policy of continuous product development and improvement renders specifications liable to modification. Information provided in this brochure is therefore subject to change without prior notification.